

## Freight Elevator Series GFC-L3



**MITSUBISHI ELECTRIC BUILDING SOLUTIONS CORPORATION**

HEAD OFFICE : TOKYO BLDG., 2-7-3, MARUNOUCHI, CHIYODA-KU, TOKYO 100-8310, JAPAN

[www.MitsubishiElectric.com/elevator](http://www.MitsubishiElectric.com/elevator)

 **Safety Tips:** Be sure to read the instruction manual fully before using this product.

# GFC-L3 The Best Helper to Enhance the Efficiency of your Modern Factory

## Comfort

- Smooth riding comfort
- Universal design
- Creating comfortable building environments

## Comfort

## Efficiency

## Efficiency

- Promoting energy-savings with cutting-edge drive/control technologies
- Improving efficiency of building management and transportation in buildings
- Pursuing space-saving developments

Quality  
in Motion

## Safety

- Ensuring safety during boarding and exiting and at the time of an emergency
- Developing highly durable and safe service systems
- Offering advanced building security

## Safety

## Ecology

## Ecology

- Saving resources through downsizing and weight reduction
- Using environmentally conscious materials
- Promoting eco-factories

\* Quality in Motion is a trademark of Mitsubishi Electric Corporation.

## ADVANCED TECHNOLOGIES

### | Energy Saving, Permanent Magnet Motor

GFC-L3 freight elevator equipped with high efficient permanent magnet motor. Through the advanced technology of permanent magnet motor, brings more comfortable and quiet riding for the passengers. Moreover, it saves more electricity compared with the traditional worm gear driven traction machine.

### | Variable Voltage Variable Frequency (VVVF) Control System

The application of VVVF control to the freight elevator is a great breakthrough of technology. Not only does it provide smooth and steady operation, but also greatly improves the efficiency of energy utilization to achieve more energy saving performance.

### | Data Network with Artificial Intelligence and Friendly Man-Machine Interfacing

The elevator system configures with a data network. Developed using leading edge technology, it connects with microprocessors at each distributed modules through a serial transmission line. Each module is assigned appropriate intelligent features, resulting in a substantial improvement in man-machine interfacing. A mutual check function ensures further reliability and efficiency in data.

### | More User Friendly Operating Features

To ensure the safety and smooth riding for both passengers and goods, the new series GFC-L3 freight elevator employs more user friendly features. They have been strictly tested and simulated in the factory before delivery, thus the reliability is greatly improved and possibility of breaking down is reduced.



Energy saving, permanent magnet motor.



Type FCD-A

Specification

Car Type	FCD-A	FCD-B
Lighting	LED lighting through embed milky-white resin flat covers	LED lighting through embed milky-white resin covers
Ventilation equipment	Diffuser	Electric blower with slit vents
Walls and doors	Painted steel sheet Stainless steel hairline (Optional)	
Entrance columns	Stainless steel hairline	
Car wall protection plate	Stainless steel hairline (for painted steel walls only)	
Flooring	Steel checker plate with black paint Durable vinyl tile (Optional)	
Sill	Extruded hard aluminum (Capacity of 2,000kg or less) Steel plate with black paint (Capacity over 2,000kg)	



Type FCD-B

Detailed disposing of fan and lighting, please consult our local agents.



Specification

Door frame	Painted steel sheet
	Stainless steel hairline (Optional)
Doors	Painted steel sheet
	Stainless steel hairline (Optional)
Sill	Extruded hard aluminum (Capacity of 2,000kg or less)
	Steel plate with black paint (Capacity over 2,000kg)



Type E-102 (Standard)

Elevator color shown is slightly different from actual tone.

## ■ Durable Vinyl Tiles (For Car Flooring)

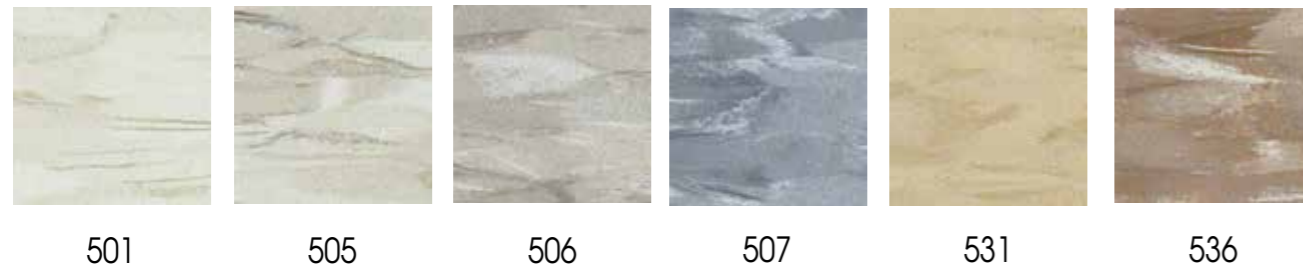

501      505      506      507      531      536

## ■ Painted Finish

(For Car Walls / Car Doors / Door Frames)



27R      37Y(A)      46YR      52YR      70Y      71Y



80G      88GY      92GY      109B      115PB

## FOR COMFORT, CONVENIENCE AND SAFETY

### | False Call Canceling-Car Button Type (FCC-P)

If the wrong car button is pressed, it can be canceled by quickly pressing the same button again twice.

### | Non-Service to Specific Floors-Car Button Type (NS-CB) [Optional]

To enhance security, service to specific floors can be disabled using the car operating panel. This function is automatically deactivated during emergency operation.

### | Repeated Door-Close (RDC)

Should an obstacle prevent the doors from closing, the doors will repeatedly open and close until the obstacle is cleared from the doorway.

### | Extended Door-Open Button (DKO-TB)

When the button inside a car is pressed, the doors will remain open longer to allow loading and unloading of baggage, a stretcher, etc.

### | Door Load Detector (DLD)

When excessive door load has been detected while opening or closing, the doors immediately reverse.

### | Mitsubishi Emergency Landing Device (MELD) [Optional]

Upon power failure, a car equipped with this function automatically moves and stops at the nearest floor using a rechargeable battery, and the doors open to ensure passenger safety.

(Maximum allowable floor-to-floor distance is 10 meters.)

(MELD is only applied below: 750~1000 kg 60~105 m/min, 1500~2500 kg 45~105 m/min.)

## Car Operating Panel



CBV2-C710E

### Buttons accented with LED halo illumination

Tactile and flat buttons (stainless-steel with non-directional hairline-finish) are available in three illumination colors: yellow-orange, white and blue.

#### Standard

Yellow-orange



Flat button  
[#]: 2

Yellow-orange



Tactile button  
[#]: 1

#### Optional

White



Tactile button  
[#]: 3

White



Flat button  
[#]: 4

Blue



Tactile button  
[#]: 5

Blue



Flat button  
[#]: 6

### Selecting button type

Input the number corresponding to the button type as the fourth digit (shown as # in this brochure) in the car operating panel type (CBV#-XXXX) and hall button type (PIV#-XXXX or HBV#-XXXX).

\*1 Segment LED indicators cannot display some letters of the alphabet. Please consult our local agents for details.

\*2 •The largest car operating panel corresponds to the 20 stops, when the height is same of cage (CH) and Entrance (HH) in 2100.

•The standard car operating panel in this image has no service cabinet. A similar car operating panel with service cabinet is available as an option.

\*3 Please select a button type, and enter the number in the space shown as #.

### Specification

Faceplate	Stainless steel hairline
Display panel	Smoky gray plastic, matte surface
Direction light and indicator	Segment LED indicator
Call button	Micro stroke click button
Response light	LED (Buttons accented with LED halo illumination)

## Hall Position Indicators



PIH-D417(Optional)



PID-D417(Optional)

Assembled into transom panel

### Specification

Faceplate	Stainless steel hairline (PIH-D417)
Display panel	Smoky gray plastic, matte surface
Direction light and indicator	Segment LED indicator (orange color when illuminated)

## Hall Buttons



HBV2-A1010  
(Optional)



HBV2-C710  
(Optional)

### Specification

Faceplate	Stainless steel hairline with button base (HBV2-A1010)
	Stainless steel hairline (HBV2-C710)
Call button	Micro stroke click button
Response light	LED (Buttons accented with LED halo illumination)

## Hall Position Indicators and Call Buttons

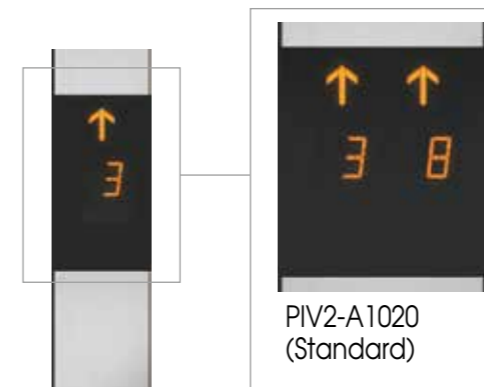

PIV2-A1010  
(Standard)



PIV2-A1020  
(Standard)

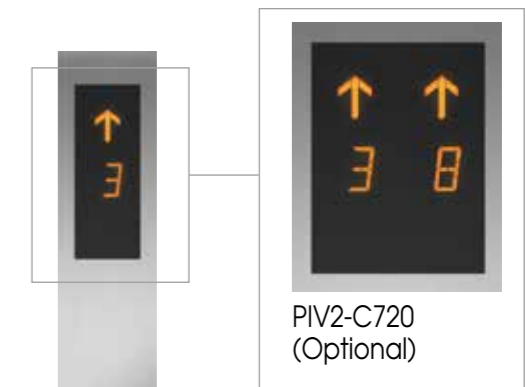

PIV2-C710  
(Optional)



PIV2-C720  
(Optional)

### Specification

Faceplate	Stainless steel hairline with button base (PIV2-A1010 / PIV2-A1020)
	Stainless steel hairline (PIV2-C710 / PIV2-C720)
Display panel	Smoky gray plastic, matte surface
Direction light and indicator	Segment LED indicator
Call button	Micro stroke click button
Response light	LED (Buttons accented with LED halo illumination)

# INSTALLATION DRAWINGS

■ 750kg (60,90,105m/min)

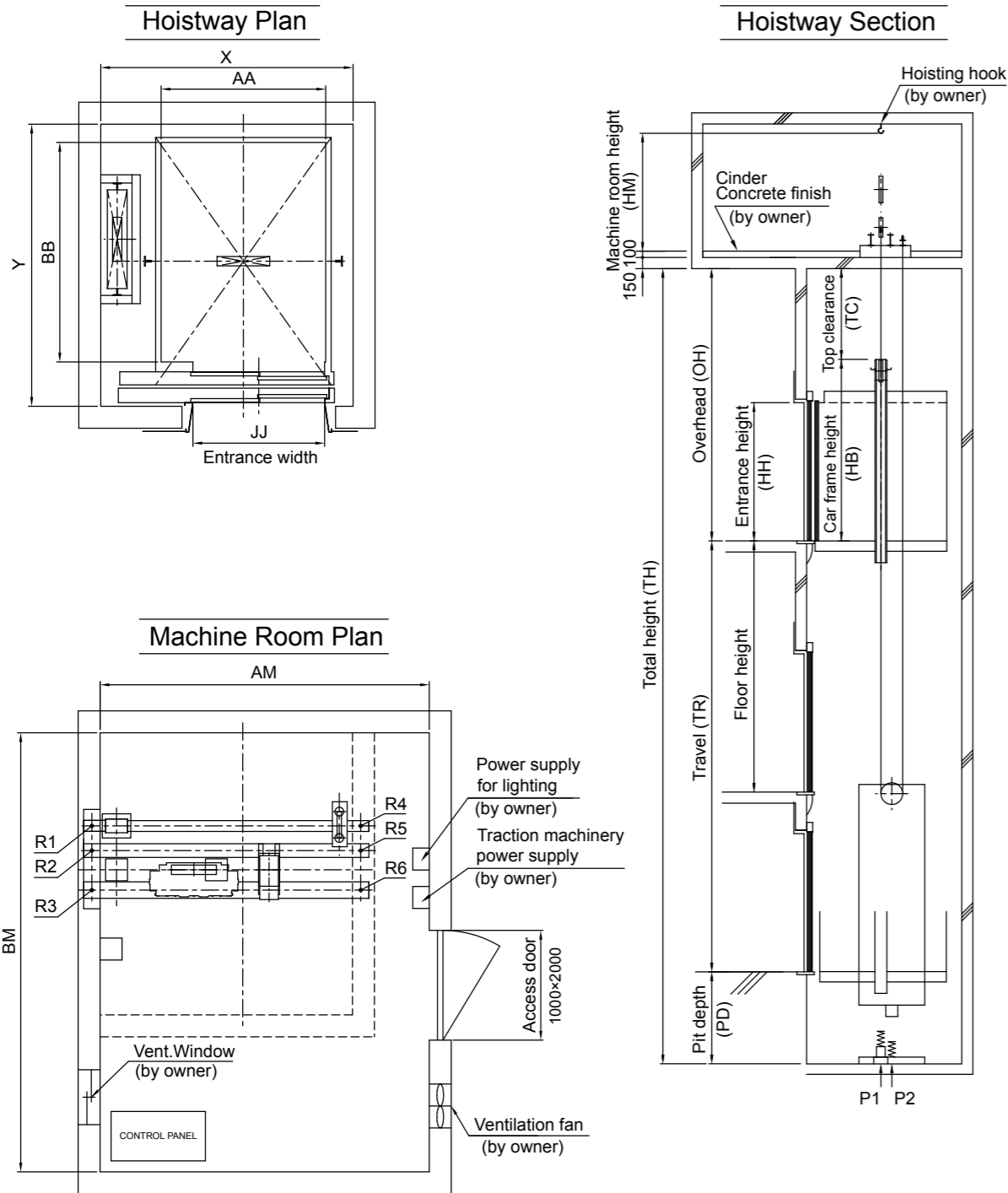

■ 1000kg (60,90,105m/min)

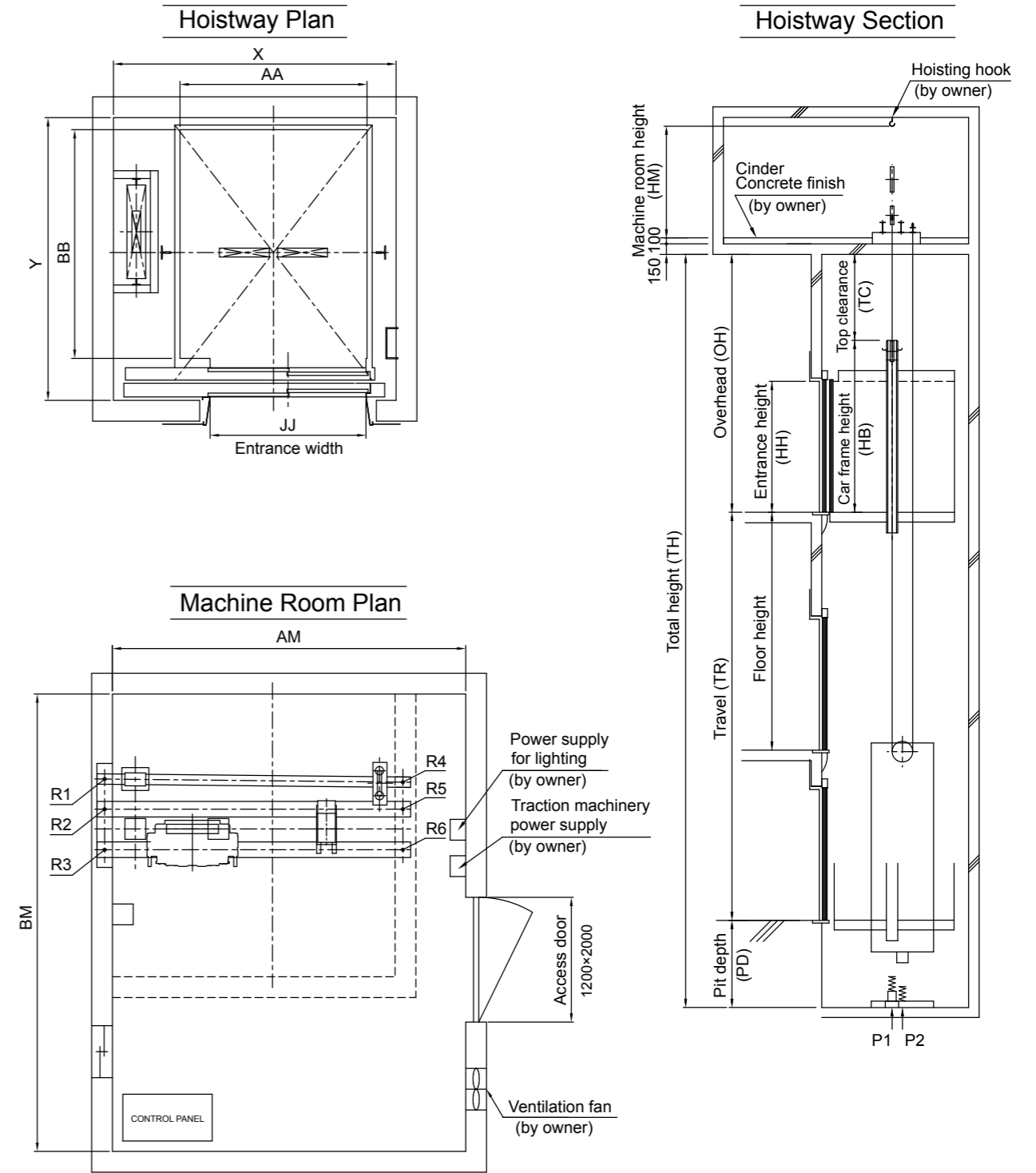

\* The above installation drawings (2:1 roping) are only applicable for rated capacity under 750kg.

\* The above installation drawings (2:1 roping) are only applicable for rated capacity under 1000kg.

## 1500kg~2500kg (45,60,90,105m/min)

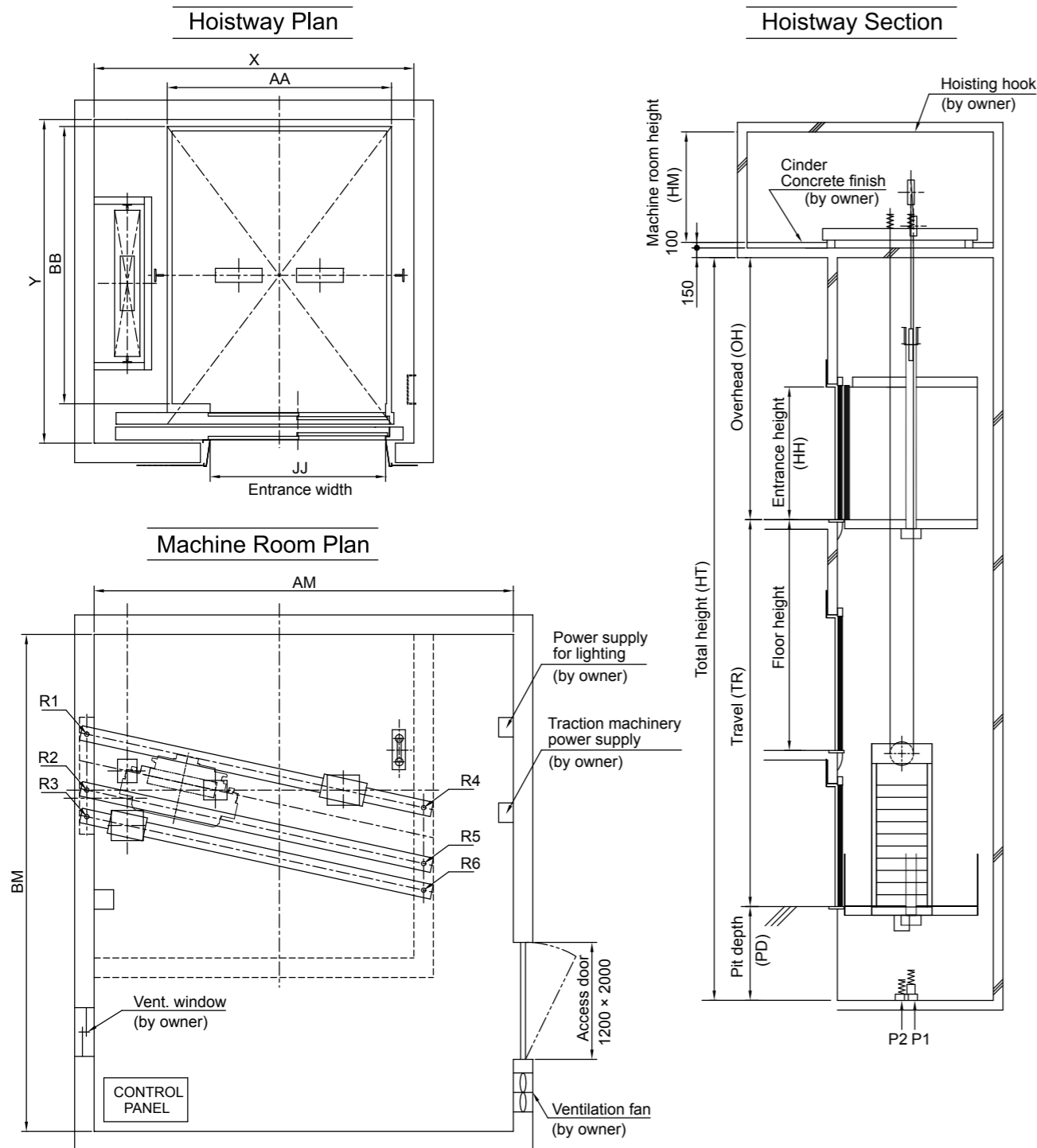

## 750kg, 1000kg (60,90,105m/min)

Rated capacity (kg)	Door type	Rated speed (m/min)	Entrance width JJ	Dimensions (mm)			Reaction loads (kN)							
				Car internal (AA×BB)	Minimum hoistway (X×Y)	Minimum machine room (AM×BM)	Machine room						Pit	
							R1	R2	R3	R4	R5	R6	P1	P2
750	2S	60	1200	1500×2000	2300×2570	3000×4000	20.6	22.6	22.3	2.1	20.3	18.9	74	63.2
		90											98	83.7
		105											102.5	87.6
1000	2S	60	1500	1800×2200	2720×2720	3400×4400	25.8	29.2	31	3	24.4	23.1	101.7	86.8
		90											134.7	114.9
		105											140.9	120.2

When CWT safety gear is required, please consult with the engineering section.

## 1500kg~2500kg (45,60m/min)

Rated capacity (kg)	Door type	Rated speed (m/min)	Entrance width JJ	Dimensions (mm)			Reaction loads (kN)							
				Car internal (AA×BB)	Minimum hoistway (X×Y)	Minimum machine room (AM×BM)	Machine room						Pit	
							R1	R2	R3	R4	R5	R6	P1	P2
1500	2S	45	1700	2200×2400	3150×3105	4000×5100	47.7	34.4	33.9	48.1	9.7	4.5	132.0	111.5
		60											139.0	117.5
2000	2S	45	1800	2200×2800	3280×3320	4300×5100	50.6	44.1	37.9	57.1	15.5	6.2	157.4	128.5
		60											165.2	135.3
2500	3S	45	2100	2500×3000	3530×3595	4500×5700	65.2	57.0	49.1	69.3	17.5	6.5	202.7	165.6
		60											213.5	174.4

When CWT safety gear is required, please consult with the engineering section.

## 1500kg~2500kg (90,105m/min)

Rated capacity (kg)	Door type	Rated speed (m/min)	Entrance width JJ	Dimensions (mm)			Reaction loads (kN)							
				Car internal (AA×BB)	Minimum hoistway (X×Y)	Minimum machine room (AM×BM)	Machine room						Pit	
							R1	R2	R3	R4	R5	R6	P1	P2
1500	2S	90	1700	2200×2400	3255×3105	4000×5100	44.8	39.7	33.6	49.5	13.7	5.7	162.0	159.1
		105											190.8	171.7
2000	2S	90	1800	2200×2800	3280×3320	4300×5100	49.2	43.6	35.8	54.2	15.6	6.0	184.0	148.5
		105											216.7	174.8
2500	3S	90	2100	2500×3000	3530×3595	4500×5700	65.2	57.0	49.1	69.3	17.5	6.5	251.6	171.7
		105											271.4	202.2

When CWT safety gear is required, please consult with the engineering section.

\* The above installation drawings (2:1 roping) are only applicable for rated capacity 1500~2500kg.

## Maximum Number Stops, Travel and Minimum Floor Height

Rated capacity (kg)	Rated speed (m/min)	Maximum number of stops	Maximum travel (m)	Minimum floor height (mm)
750~1000	60	30	60	HH+700
	90		80	
105	60			
1500			45	
			60	
	90			
2000	105			
	45			
	60			
2500	90			
	105			
	45			
	60			
	90			
	105			

## Vertical Dimensions

Rated capacity (kg)	Rated speed (m/min)	OH (mm)	PD (mm)	TC (mm)	HH (mm)	HB (mm)	HM (mm)
750	60	4650	1550	1450	2100	3200	2500
	90	4800	1800	1600			
	105	5000	2100	1800			
1000	60	4650	1550	1450	2100	3200	2650
	90	4800	1800	1600			
	105	5000	2100	1800			
1500	45	4450	1250	1250	2100	3200	2500
	60	4650	1550	1450			2650
	90	4800	1800	1600			2650
	105	5000	2100	1800			
2000	45	4450	1250	1250	2100	3200	2650
	60	4650	1550	1450			2950
	90	4800	1800	1600			2950
	105	5000	2100	1800			
2500	45	4850	1250	1250	2500	3600	2950
	60	5050	1550	1450			
	90	5200	1800	1600			
	105	5400	2100	1800			

When CWT safety gear is required, please consult with the engineering section.

OH: Overhead  
 PD: Pit depth  
 TC: Top clearance  
 HH: Entenance height  
 HB: Car frame height  
 HM: Machine room height

NOTE:  
 Freight elevators of less than 2500kg capacity can only be loaded by handtrucks with casters. Goods cannot be loaded by forklift.  
 Please consult our local agents if you plan to use a forklift to load and unload goods with our traction-type freight elevators of 2500kg capacity.

## Power Feeder Data

Capacity (KG)	Speed (m/min)	Capacity of Power Supply (KVA)	Breaker Current Rating in M/R	
			(200V)	(400V)
750	60	6	30A	15A
	90	8	50A	30A
	105	9	50A	30A
1000	60	7	40A	20A
	90	10	60A	30A
	105	11	75A	40A
1500	45	8	50A	30A
	60	10	60A	30A
	90	14	100A	50A
	105	16	100A	50A
2000	45	10	60A	30A
	60	13	75A	40A
	90	19	125A	60A
2500	105	20	150A	75A
	45	12	75A	40A
	60	16	100A	50A
	90	23	150A	75A
	105	26	175A	100A

# ENTRANCE LAYOUT

## ■ 2S Doors (E-102) (2-panel side sliding doors)

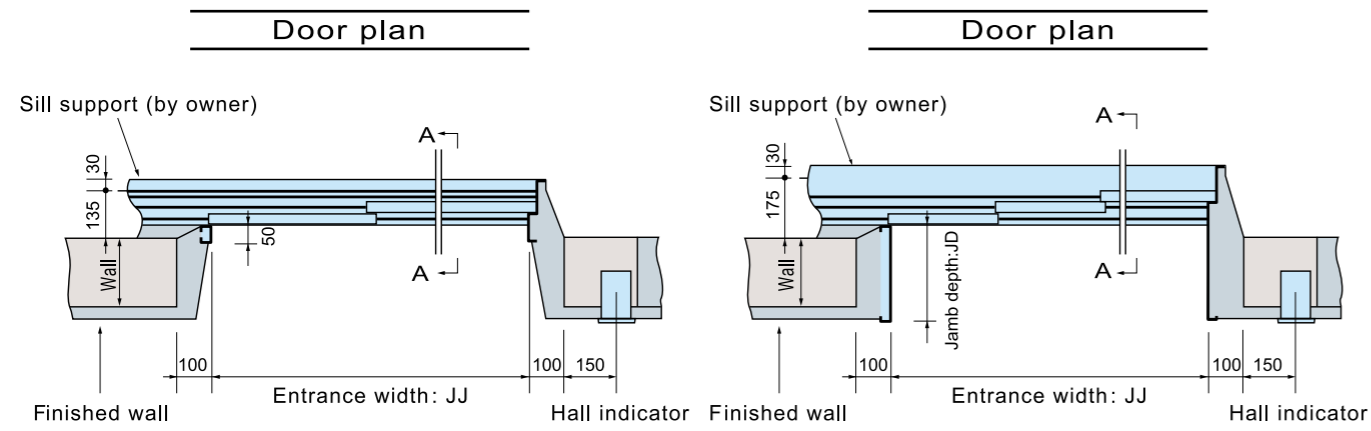

## ■ 3S Doors (E-202) (3-panel side sliding doors)

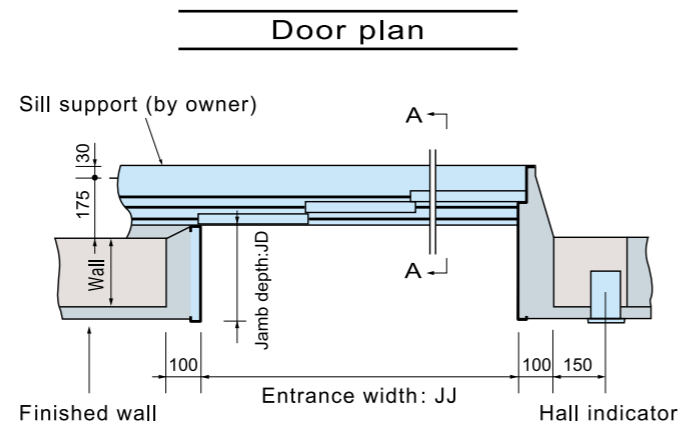

## ■ 2CO Doors (E-202) (4-panel center opening doors)

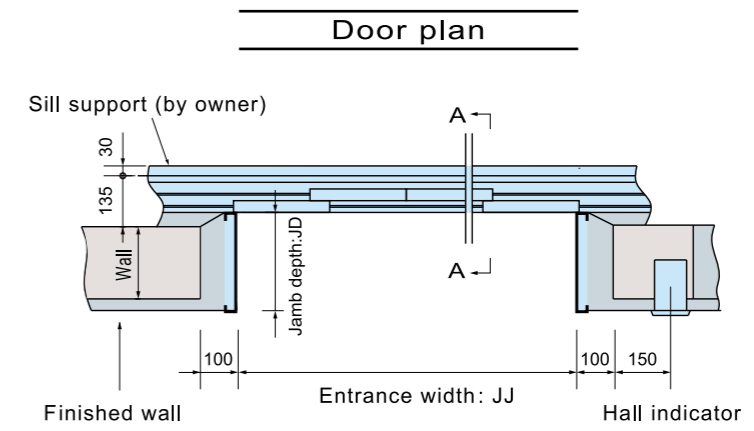

**Door elevation**  
(Section A-A)

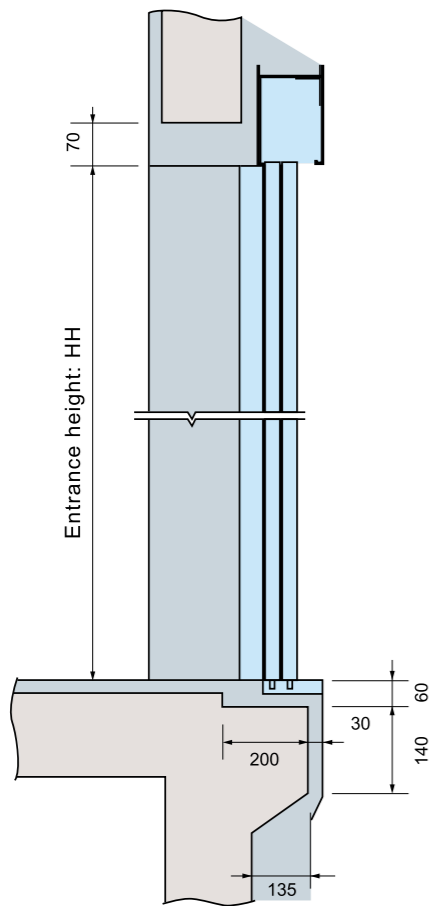

**Door elevation**  
(Section A-A)

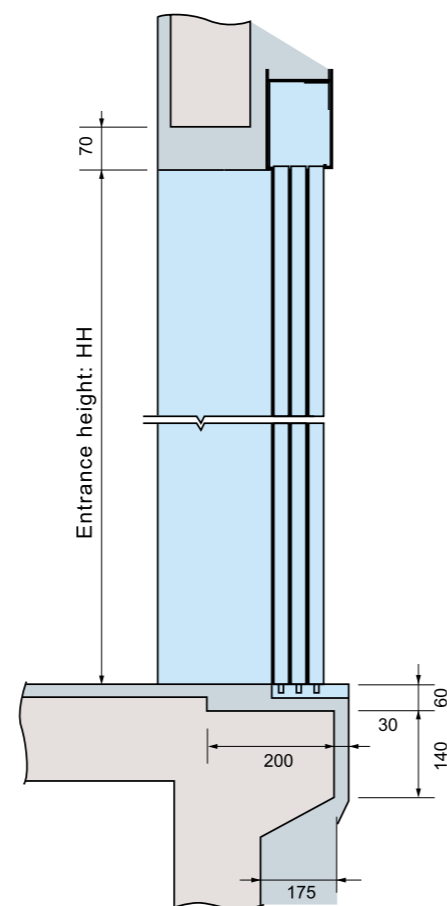

**Door elevation**  
(Section A-A)

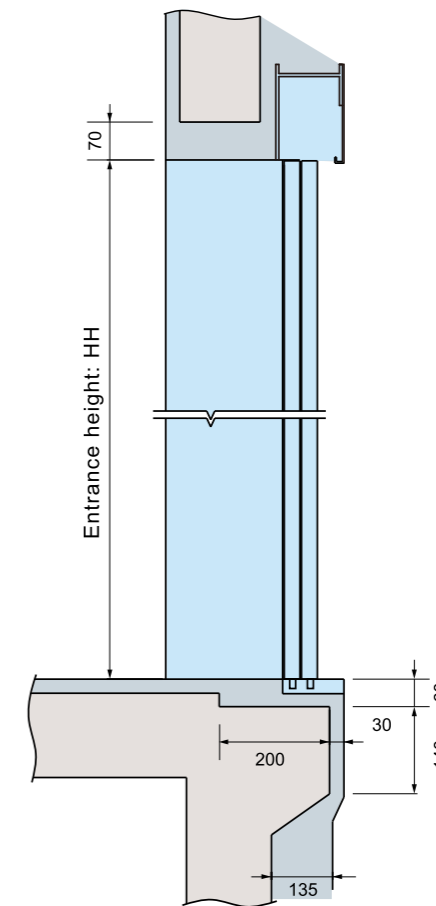

\* For other door types and JD dimension, please contact our local agents for detail.

## Table of Features (Standard)

Feature	Description
<b>■ Operation System</b>	
<b>(1C-2BC) 1 CAR Selective Collective</b>	The system consists of call buttons in the car, and a riser of up and down destination floor buttons installed at each elevator hall (single button at terminal floors), which connect electrically with microprocessors supervising floor selection and direction of travel. A car will respond to those car and hall calls that comply with its direction of service.
<b>■ Operational and Service Features</b>	
<b>(CCC) Car Call Canceling</b>	When a car has responded to the final car call in one direction, the system regards remaining calls in the other direction as mistakes and clears them from the memory.
<b>(OLH) Overload Holding Stop</b>	A beep, as well as voice guidance, sounds to alert the passengers that the car is overloaded: the doors remain open and the car does not leave that floor until enough passengers exit the car.
<b>(SFL) Safe Landing</b>	If a car has stopped between floors due to some equipment malfunction, the controller checks the cause, and if it is considered safe to move the car, the car will move to the nearest floor at a low speed and the doors will open.
<b>(CFO-A) Car Fan Shut Off Automatic</b>	If there are no calls for a specified period, the car ventilation fan will automatically be turned off to conserve energy.
<b>(CLO-A) Car Light Shut Off Automatic</b>	If there are no calls for a specified period, the car lighting will automatically shut off to conserve energy.
<b>(FCC-A) False Call Canceling Automatic</b>	If the number of registered car calls does not correspond to the car load, all calls are canceled to avoid unnecessary stops.
<b>(IND) Independent Service</b>	Exclusive operation where a car is withdrawn from group control operation for independent use, such as maintenance or repair, and responds only to car calls.
<b>(FCC-P) Car Call Erase</b>	If the wrong car button is pressed, it can be canceled by quickly pressing the same button again twice.

Feature	Description
<b>■ Door Operation features</b>	
<b>(DLD) Door Load Detector</b>	When excessive door load has been detected while opening or closing, the doors immediately reverse.
<b>(DODA) Door Sensor Self-diagnosis</b>	Failure of non-contact door sensors is checked automatically, and if a problem is diagnosed, the door-close timing is delayed and the closing speed is reduced to maintain elevator service and ensure passenger safety.
<b>(DOT) Automatic Door-open Time Adjustment</b>	The time doors are open will automatically be adjusted, depending on whether the stop was called from the hall or the car, to allow smooth boarding of passengers or loading of baggage.
<b>(DSAC) Automatic Door Speed Control</b>	Door load on each floor, which can depend on the type of hall door, is monitored to adjust the door speed, thereby making the door speed consistent throughout all floors. (Cannot be used with some doors.)
<b>(RDC) Repeated Door-Close</b>	Should an obstacle prevent the doors from closing, the doors will repeatedly open and close until the obstacle is removed.
<b>(ROHB) Reopen with Hall Button</b>	Closing doors can be reopened by pressing the hall button corresponding to the traveling direction of the car.
<b>(SDE) Safety Door Edge</b>	Sensitive door edges detect passengers or objects during door closing.
<b>(DKO-TB) Extended Door-Open Button</b>	A button located inside a car which keeps the doors open for a longer than usual period to allow loading and unloading of a stretcher, baggage, etc.
<b>■ Signal and Display Features</b>	
<b>(ITP) Inter Communication System</b>	A system which allows communication between passengers inside a car and the building personnel.
<b>■ Emergency Operations and Features</b>	
<b>(ECL) Emergency Car Lighting</b>	Car lighting which turns on immediately when power fails to provide a minimum level of lighting within the car. (Choice of dry-cell battery or trickle-charger battery.)

## Table of Features (Optional)

Feature	Description
<b>Operational and Service Features</b>	
<b>(ABP) Automatic Bypass</b>	A fully-loaded car bypasses hall calls in order to maintain maximum operational efficiency. (Optional in case of 1-car 2BC system.)
<b>(AS) Attendant Service</b>	Exclusive operation where an elevator can be operated using the buttons and switches located in the car operating panel, allowing smooth boarding of passengers or loading of baggage.
<b>(HOS) Out-of-Service by Hall Key Switch</b>	For maintenance or energy-saving measures, a car can be taken out of service temporarily with a key switch (with or without a timer) mounted in a specified hall.
<b>(NS-CB) Non-Service to Specific Floors – Car Button Type</b>	To enhance security, service to desired floors can be set to disable using the car operating panel. This function is automatically deactivated during Emergency Operations.
<b>(NS/NS-T) Non-Service to Specific Floors – Switch/Timer Type</b>	To enhance security, service to desired floors can be set to disable using a manual or timer switch. This function is automatically deactivated during Emergency Operations.
<b>(SCS-B) Secret Call Service</b>	To enhance security, car calls for desired floors can be registered only by entering secret codes using the car buttons on the car control panel. This function is automatically deactivated during Emergency Operations.
<b>Door Operation features</b>	
<b>(SR) Safety Ray</b>	One or two infrared-light beams cover the full width of the doors as they open or close to detect passengers or objects. (Cannot be combined with multi-beam door sensor.)
<b>(MBS) Multi-beam Door Sensor</b>	Multiple infrared-light beams cover a door height of approximately 1800mm to detect passengers or objects as the doors close. (Cannot be combined with the SR feature.)

Feature	Description
<b>Signal and Display Features</b>	
<b>(AECC/AECH) Car Arrival Chime – Car or Hall</b>	Electronic chimes sound to indicate that a car will soon arrive. (The chimes are mounted either on the top and bottom of the car, or in each hall.)
<b>(EXCL) Excluding Operation Signal Light</b>	As the Reserved Operation for Emergency (HE-B) function is started, hall indicator instructs the lantern fair to light special-purposely, remind and take advantage of hall passenger's changing to take other lifts
<b>(FHL) Flashing Hall Lantern</b>	A hall lantern, which corresponds to a car's service direction, flashes to indicate that the car will soon arrive.
<b>Emergency Operations and Features</b>	
<b>(EER-S/P) Earthquake Emergency Return</b>	Upon activation of secondary wave seismic sensors, all cars stop at the nearest floor, and park there with the doors open to facilitate safe evacuation of passengers.
<b>(FER) Fire Emergency Return</b>	Upon activation of a key switch or a building's fire sensors, all calls are canceled, all cars immediately return to a specified evacuation floor and the doors open to ensure safe passenger evacuation.
<b>(OEPS) Operation by Emergency Power Source – Automatic/Manual</b>	Upon power failure, the building's emergency power moves and stops pre-determined car(s) to a specified floor, and the doors open to ensure passenger safety. After all predetermined car(s) have arrived at the floor, normal operation will be available with only pre-determined car(s).
<b>(WP) Supervisory Panel</b>	A panel installed in a building's supervisory room, etc., which monitors and controls each elevator's status and operations by remote, using indicators and switches which are provided on request.
<b>(MELD) Mitsubishi Emergency Landing Device</b>	Upon power failure, a car equipped with this function automatically moves and stops at the nearest floor using a rechargeable battery, and the doors open to ensure passenger safety. (Max. allowable floor-to-floor distance is 10 meters.) (MELD is only applied below: 750~1000 kg 60~105 m/min, 1500~2500 kg 45~105 m/min.)
<b>(WP-W)MeEye Mitsubishi Elevators &amp; Escalators Monitoring and Control System</b>	Each elevator's status and operation can be monitored and controlled using an advanced Web-based technology which provides an interface through personal computers. Special optional features such as preparation of traffic statistics and analysis are also available.
<b>(HE-B) Reserved Operation for Emergency – Block Sign Type</b>	In the state of emergency, the lift can discontinue the service for other floors temporarily, transport the urgent patient directly.

